

War Field Spying Robot Using Wireless Camera

¹Kunj Gudhka, ²Aishwarya Kadam, ³Devika Kale, ⁴Manil Rupani,
⁵Prof. Tilottama Dhake

K.J. Somaiya Institute of Engineering & Information Technology, University of Mumbai, India

Abstract: Nowadays as there are technological advancements these advancements are used by the military forces for reducing the risk of their casualties and to defeat their enemies. With the development of sophisticated technology, it mostly relies on the high tech weapons or machinery being used. Robotics is one of the hot fields of modern age in which the nations are concentrating upon for military purposes in the state of war and peace. They have been in use for some time for demining and rescue operations but now they are propelled by using them for combat and spy missions. Modern military forces are using different kinds of robots for different applications ranging from mine detection to rescue operations. In future, they will be used for reconnaissance and surveillance, logistics and support, communications infrastructure, forward-deployed offensive operations, and as tactical decoys to conceal maneuver by manned assets. In order to make robots efficient for the unpredicted cluttered environment of the battlefield, research on different aspects of robots are under examination in laboratories to be able to do its job autonomously, as efficiently as a human operated machine can do. Latest technologies, software and hardware are being investigated to have advanced and intelligent robots for different operations on the war field. This paper presents robotic technologies being used in war spying. These robots are under examination for autonomous, co-operative and controlled environment. Our major focus is on the uses of robots in war, peace and as well as their impact on society.

Keywords: wireless, robot, RF technology, transmission, reception, war, spy, surveillance.

I. INTRODUCTION

Robotics is the branch of mechanical engineering, electrical engineering and computer science that deals with the design, construction, operation and application of robotics, ^[1] as well as computer systems for their control, sensory feedback and information processing.

The aim of developing a high-tech technology serves the purpose of achieving high speed technology, advanced capacity to control the robots and to devise new methods of control theory. The realization of above standards some technical improvement along with the need of high performance robot is required to create a faster, reliable, accurate and more intelligent robot which can be devised by advanced control algorithm, robot control devices and new drivers.

The design of our project encourages developing a robotic vehicle based on RF technology for the remote operation connected with the wireless camera mounted on the robot for monitoring purpose. The transmitting module consist of the push buttons that send the commands to the receiving module for controlling the movement of robot either to right, left, forward, downward. In the receiving module of the robot two motors are interfaced with the decoder HT12D to control its movement via L293D motor driver IC. The remote control (RF transmitter) has a range of 50m to 200m that transmits the signals to the RF receiver. The receiver collects and decodes the received signals before feeding it to the microcontroller to drive the DC motors via motor drivers.

II. RF COMMUNICATION

Radio frequency (RF) is any of the electromagnetic wave frequencies that lie in the range extending from around 3 kHz to 300 GHz, which include those frequencies used for communications or radar signals. In order to receive radio signals an antenna must be used. This antenna will pick up thousands of radio signal at a time and for the same we need to use a radio tuner to tune into a particular frequency. This is done by using a resonator. Resonator amplifies oscillations within a frequency band while reducing the oscillations at other frequency outside the band.

In our project we are using RF 433 MHz RF module along with HT12E (Encoder) and HT12D (Decoder). Transmission of data or commands are done using the RF module while the encoder and decoder are used for controlling the robot and other interfaces.

This is a 4 bit wireless module. Use it to transmit and receive 4 bits of data through a wireless RF Link. It uses our 433 MHz RF Modules and the HT12E/D IC. The transmitter and the receiver come with an 8 bit address selector switch which can be used to assign unique addresses to each wireless link. Receivers receive data only from transmitters which have a matching 8 bit address. The module can operate within a range of 100m when the transmitter is in line of sight and around 50m when indoors.

This module takes care of all the encoding and decoding required to transmit data and requires no additional computation by the micro controller. Users can directly hook up the module to a micro controller and start transmitting data wirelessly. The transmitter and the receiver can be directly connected to a microcontroller or an external circuit through the header pins.

RF communication has two sections RF 433 MHz Transmitter with HT12E (Encoder) and RF 433Mhz Receiver with HT12D (Decoder).

A. RF 433 MHz Transmitter with HT12E:

In this section a brief introduction about RF 433 MHz Transmitter and HT12E (Encoder) is given individually following with the interface of the encoder with the transmitter.

This is a Hybrid 433Mhz RF transmitter & receiver module and is ideal for short-range wireless control applications where quality is a primary concern. The receiver module requires no external RF components except for the antenna. The super-regenerative design exhibits exceptional sensitivity at a very low cost.

RF Transmitter 433 MHz ASK Features:

- Transmitter Frequency: 433.92 MHz
- Range: 500ft (For perfect given conditions).
- Data Rate: 8Kbps.
- Supply voltage: 1.5~12 Volts.
- Circuit Shape: Saw Type
- Output Power: 14dBm
- Working temperature: -20 ~ +85 Celsius
- Solder temperature: 230 Celsius (10 seconds).
- High sensitivity is designed.

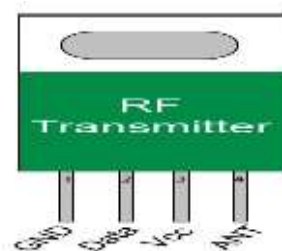

Fig.1 RF Receiver

RF TRANSMITTER:

- Pin 1 — Ground [GND]
- Pin 2 — Serial data input pin [DATA]
- Pin 3 — Power supply; 5v [Vcc]
- Pin 4 — Antenna Output pin [ANT]

HT12E (Encoder):

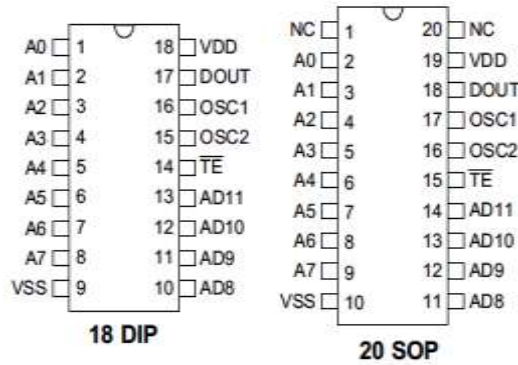

Fig.2 HT12E (Encoder)

- **VDD and VSS** are power supply pins which are used to connect positive and negative of the power supply respectively.
- **OSC1 and OSC2** are used to connect external resistance for the internal oscillator. OSC1 is the oscillator input pin and OSC2 is the oscillator output pin.
- **TE** is used for enabling the transmission and is an active low input.
- **A0 – A7** are the input address pins. By using these pins we can provide a security code for the data. These pins can be connected to VSS or left open.
- **D8 – D11** are the input data pins. These pins can be connected to VSS or may left open for sending LOW and HIGH respectively.
- **DOUT** – It is the serial data output of the encoder and can be connected to a RF transmitter.

RF 433 MHz ASK Transmitter interface with HT12E:

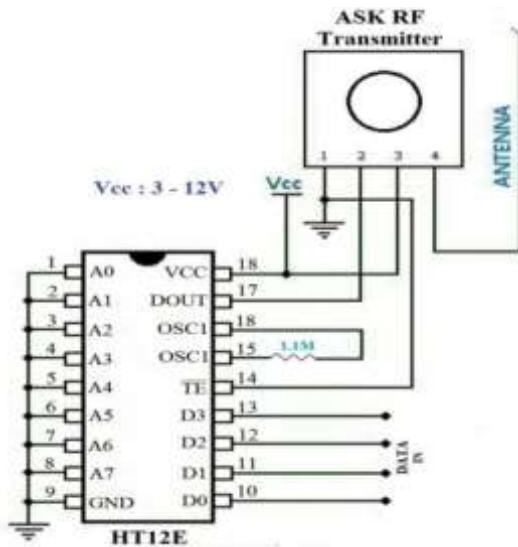

Fig.3 Transmitter section

The above figure shows us the interface of the transmitter and the encoder. The encoder will convert 4 bit parallel data [D0-D3] to serial data through DOUT. The output received at DOUT is then given to ASK RF Transmitter. To provide data security address inputs [A0-A7] are used which are connected to ground [Logic ZERO] or left open [Logic ONE]. Transmission Enable [TE] has to be LOW for transmitting data. Transmission is only possible when there is a match of address pins of transmitter and receiver. For the operation of internal oscillator of HT12E, 1.1MΩ resistor gives the required external resistance.

B. RF 433 MHz Receiver with HT12D:

In this section a brief introduction about RF 433 MHz Receiver and HT12D (Decoder) is given individually following with the interface of the decoder with the receiver.

RF 433 MHz ASK Receiver:

This is a Hybrid 433Mhz RF receiver module and is ideal for short-range wireless control applications where quality is a primary concern. The receiver module requires no external RF components except for the antenna. The super-regenerative design exhibits exceptional sensitivity at a very low cost.

RF Receiver 433 MHz ASK Features:

- Integrated IF and data filters.
- Receiver Frequency: 433.92 MHZ
- Typical sensitivity: -110dBm
- Supply Current: 2.85mA
- IF Frequency: 280KHz
- Low power consumption.
- Operation voltage: 5 Volts.

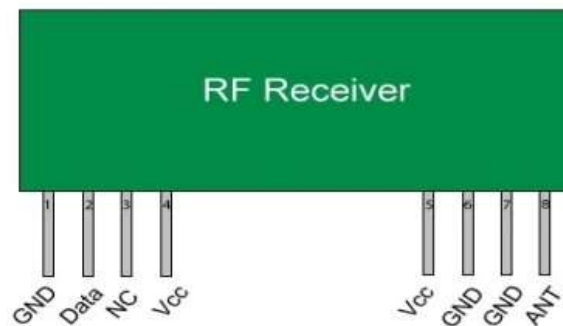

Fig.4 RF Receiver

RF RECEIVER:

- Pin 1 — Ground [GND]
- Pin 2 — Serial data output pin [DATA]
- Pin 3 — Linear output pin (Not connected) [NC]
- Pin 4 — Power supply; 5v [Vcc]
- Pin 5 — Power supply; 5v [Vcc]
- Pin 6 — Ground [GND]
- Pin 7 — Ground [GND]
- Pin 8 — Antenna Input pin [ANT]

HT12D (Decoder):

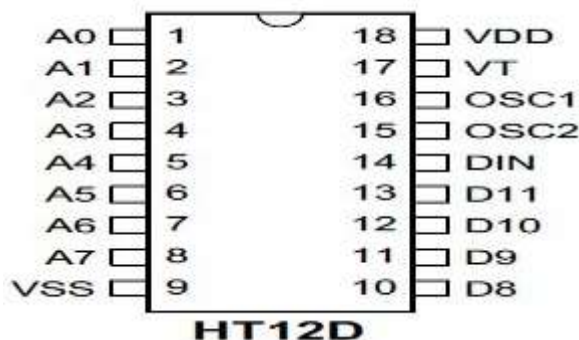

Fig.5 HT12D (Decoder)

VDD and VSS: This pin are used to provide power to the IC, Positive and Negative of the power supply respectively

DIN: This pin is the serial data input and can be connected to a RF receiver output.

A0 – A7: This are the address input. Status of these pins should match with status of address pin in HT12E (used in transmitter) to receive the data. These pins can be connected to VSS or left open

D8 – D11: This are the data output pins. Status of these pins can be VSS or VDD depending upon the received serial data through pin DIN.

VT: stand for Valid Transmission. This output pin will be HIGH when valid data is available at

D8 – D11 data output pins.

OSC1 and OSC2: This pin are used to connect external resistor for internal oscillator of HT12D. OSC1 is the oscillator input pin and OSC2 is the oscillator output pin.

RF 433 MHz ASK Receiver interface with HT12D:

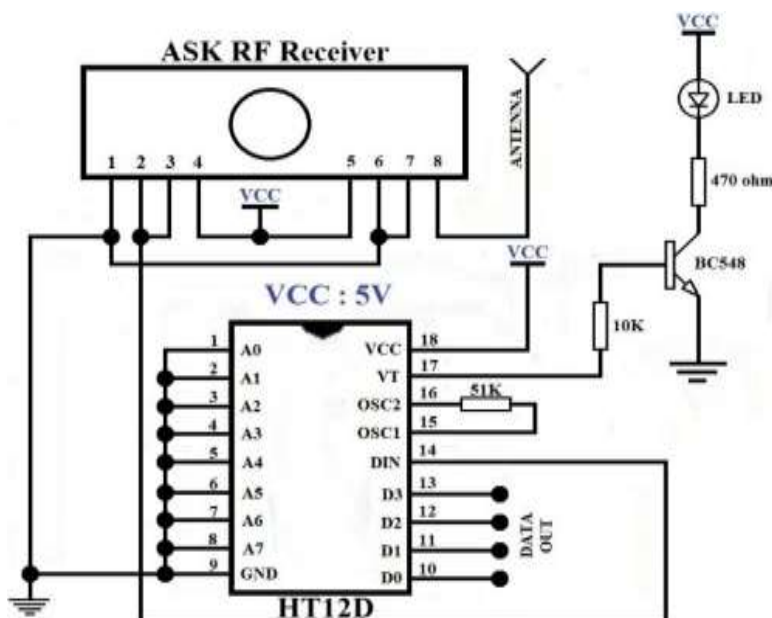

Fig.6 Receiver section

The above figure shows us the interface of the receiver and the decoder. This is the receiver section of the robot the RF receiver receives information or commands from the transmitter and sends them to the Data input pin of the decoder the decoder then decodes the data and helps us control the motor using IC L293D motor driver. IC L293D motor driver controls the movement of the robot after the decoder receives the data and decodes it. The interface of the motor driver will be seen in detail in the next section.

III. L293D MOTOR DRIVER

L293D is the most commonly used driver for bidirectional motor driving applications. L293D is a 16 pin motor driver IC which is used to drive the motors. L293D is a dual H-bridge motor driver. It can be used to drive direct current on either direction. L293D can control two DC motors simultaneously in either direction. It is used as a current amplifier since it takes low current control signal as the input and provides high current signal as output. L293D can be used to drive small as well as big motors as well.

L293D motor driver is available for providing user with ease and user friendly interfacing for embedded applications. It is easily compatible with any of the systems. It supports external power supply pins for motors.

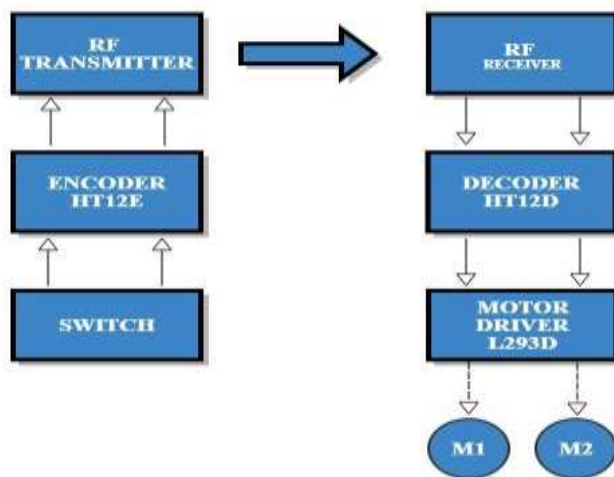

Fig.7 Flowchart of Interface of Robot

A. CONCEPT:

L293D works on the concept of H Bridge. It allows the high voltage to be flown in either direction. In a single L293D motor driver there are two H-bridge circuits which helps to rotate two dc motors independently.

B. PIN DIAGRAM:

Pin 1 and Pin 9 are two Enable pins in L293D. Both these pins need to be high for being able to drive the motor. Since there are Two H- Bridge, there are two Enable pins in L293D. For driving the motor with left H-bridge, Pin 1 should be high and for driving the motor with right H-bridge, Pin 9 should be enabled high.

There are four input pins, Pin 2 and 7 on the left and Pin 10 and 15 on the right. Pin 2 and 7 which are on the left side will drive the motor connected on the left side while Pin 10 and 15 which are on the right will regulate the rotation of the motors connected on the right side. Voltage is applied at Pin 8. The maximum voltage that can be applied to drive the motors is 36V. The maximum current applied is 600mA.

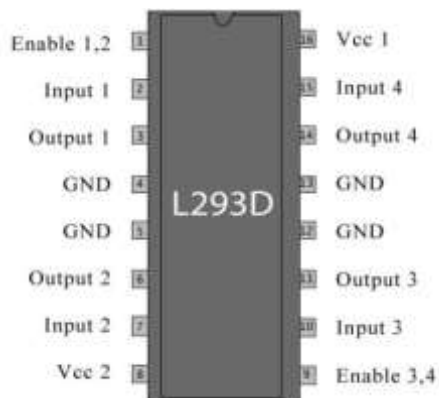

Fig.8 L293D Motor Driver

C. LOGIC TABLE:

L293D drives two motors simultaneously, both in forward and reverse direction. Motor 1 direction can be controlled using input pins 2 and 7 while the direction of Motor 2 can be controlled using input pins 10 and 15. The motors are operated with the voltage applied at Pin 8.

- Pin 2 = Logic 1 and Pin 7 = Logic 0 -> Motor 1 Clockwise direction
- Pin 2 = Logic 0 and Pin 7 = Logic 1 -> Motor 1 Anticlockwise direction
- Pin 2 = Logic 0 and Pin 7 = Logic 0 -> Motor 1 Idle
- Pin 2 = Logic 1 and Pin 7 = Logic 1 -> Motor 1 Idle
- Pin 10 = Logic 1 and Pin 15 = Logic 0 -> Motor 2 Clockwise direction
- Pin 10 = Logic 0 and Pin 15 = Logic 1 -> Motor 2 Anticlockwise direction
- Pin 10 = Logic 0 and Pin 15 = Logic 0 -> Motor 2 Idle
- Pin 10 = Logic 1 and Pin 15 = Logic 1 -> Motor 2 Idle

L293D INTERFACING WITH HT12D:

The decoded data received by HT12D decoder is given to the input pins of L293D motor driver to drive the DC motors. The data pins 10 and 11 of HT12D are connected to the input pins IN1 and IN2 of L293D respectively to drive the motor 1. The data pins 12 and 13 of HT12D are given to input pins IN3 and IN4 of L293D respectively to drive the motor 2.

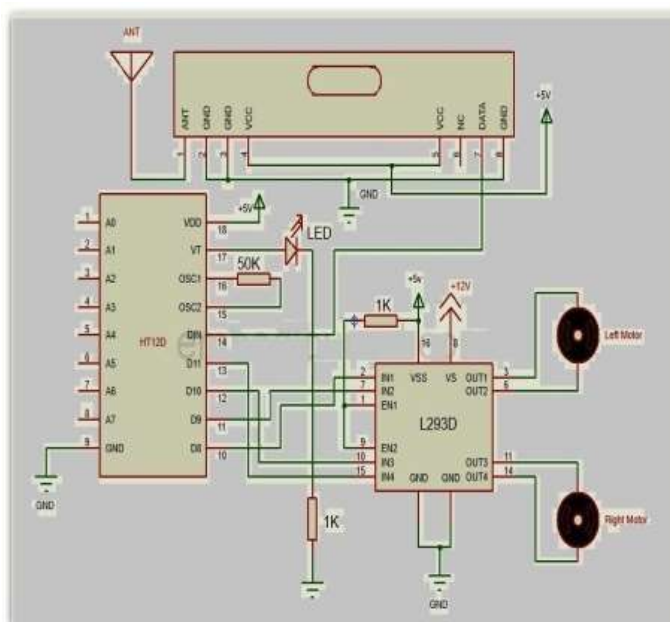

Fig.9 Interface of L293D with Receiver section

IV. WIRELESS CCD CAMERA

Wireless CCD camera is used to send live audio and video signals from the war field. These images can be seen live on a monitoring screen at the base station and accordingly we can react to the situation. The camera works on 12 volts DC supply. The receiver is placed in the remote station. Output are in the form of audio and video signals. These signals are directly sent to a television or a computer through a tuner card. This CCD camera is placed on the robot. The camera captures the audio and video signals and sends those signals to the remote station. With the help of the camera receiver we will be able to see the captured signals on a television or any monitoring device. This is a mini wireless monitoring video camera and wireless receiver set for surveillance and security. We install the wireless camera in the area where we want to monitor and set the wireless receiver in the remote station to watch the action or record the footage for the security purpose. Here we are placing this wireless camera in the combat robot which would be present in the war field.

V. CONCLUSION

The main motive of the war spying robot was to make it user friendly. The spy robot can easily move, capture images and wirelessly transmit them, thus giving the soldiers an intimation about the dangers and situations in the war field. The robot will move depending on the motor direction based upon the input we give through transmitter (remote) section. RF signals are used as control signals. By using these signals encoding is done & signal is sent through the transmitter. At the receiver end, these decoded signal are given as input to drive the motor. The robot is used for short distance surveillance thus ensuring the security of the region. This helps the forces to view the things accurately that are currently happening in the surrounding area and to plan ahead accordingly.

REFERENCES

- [1] Mr. Lokesh Mehta, Mr. Pawan Sharma “Spy Night Vision Robot with Moving Wireless Video Camera”. International journal of research in engineering technology and management (IJRETM), 2014.
- [2] Abdus Samad1, JadhavDevidasDasharath, DhaigudeMadhukar Kumar “An Intelligent Combat Robot” International Journal of Advanced Research in Computer and Communication Engineering Vol. 3, Issue 5, May 2014
- [3] AaruniJha, Apoorva Singh, RavinderTurna, Sakshi Chauhan “War Field Spying Robot With Night Vision Camera” Journal of Network Communications and Emerging Technologies (JNCET) Volume 2, Issue 1, May (2015)
- [4] Dhiraj Singh Patel “Mobile Operated Spy Robot” International journal of emerging technology and advanced engineering (IJETA), 2013.
- [5] HT12E datasheet http://www.engineersgarage.com/sites/default/files/HT12E_0.PDF
- [6] HT12D datasheet http://www.eleinmec.com/datasheets/ds_holtek_ht12d.pdf
- [7] <http://www.electronicshub.org/remote-operated-spy-robot-circuit/>
- [8] <http://www.scribd.com/doc/222143724/Major-Project-Report-on-War-Field-Spy-Robot#scribd>
- [9] <https://electrosome.com/wireless-transmitter-and-receiver-using-ask-rf-module/>
- [10] DC motors http://www.extremeelectronics.co.in/avrtutorials/pdf/avr_tutorial7---motor-control.pdf